

TEMPERATURE REGULATING AND LIMITING CONTROLS

T103, L107, L117, T125 SERIES



HIGHLIGHTS

- Construction Variables to Meet Diverse Specifications
- High Level of Accuracy and Sensitivity
- Remote Sensing
- Multi-Positional Mounting Offers Flexibility in New or Existing Installations
- UL, UL Canada, CSA, CE Approved

PECO regulating and limiting controls are designed and manufactured to meet a wide variety of specifications. These variables include mounting brackets, capillary fittings, switch terminations, and either copper, stainless steel, or plated copper bulb and capillary. The information on this sheet is intended to be general in nature. PECO has the capability to meet your specifications for required construction variables and applications.

REGULATING/ LIMITING CONTROLS

Regulating controls are used as the primary operating control. Limiting controls are back-up controls used in combination with temperature regulating controls. The operating point of limit controls is normally set higher than regulating controls and is determined by requirements of the equipment manufacturer.

Common applications for PECO regulating and limiting controls include: commercial cooking equipment such as coffee brewers, fryers, cookers, and ovens; industrial equipment such as liquid heating, plating tanks, and processing equipment; immersion heaters, duct heaters, booster heaters, etc.

TEMPERATURE REGULATING AND LIMITING CONTROLS

T103 SERIES - Heating/ Cooling Remote Sensing Thermostat

The T103 single pole, single or double throw (SPST & SPDT) remote bulb temperature controls accommodate many switching variations for heating and/or cooling applications. They mount in any position and are sensitive, stable, and responsive. Applications include control of fan coils, heat pumps, fans, air conditioners, ventilators, and coolers.

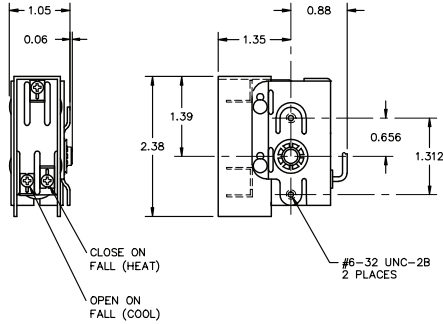

T125 SERIES - Commercial Grade Remote Sensing Thermostat

The T125 single pole, single throw (SPST) thermostats open on temperature rise, with snap action devices for a variety of liquid or air sensing applications. Their principal use is as a regulating control but some models may also have application as a limiting control. These controls are designed for precision, durability, and accuracy.

The TA125 and TB125 models are for direct switching of electrical loads. TC125 models contain a hermetically sealed switch mechanism and are for pilot duty and millivolt or low level electrical loads where the operating environment may cause contact contamination.

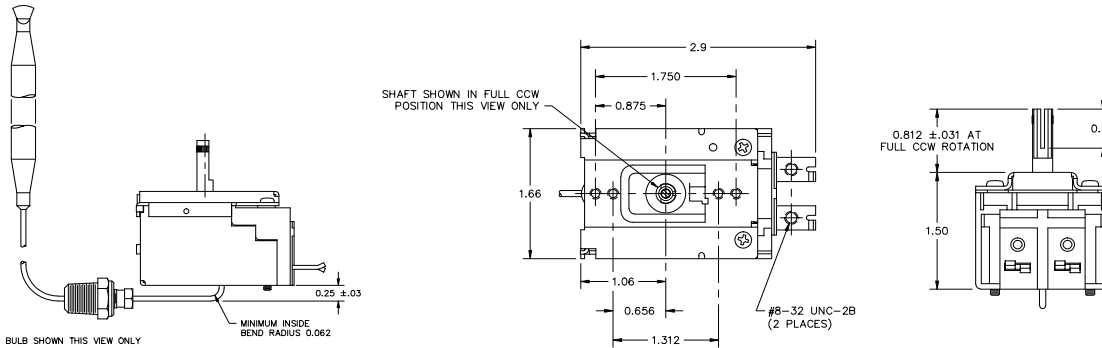

BASE MODEL SELECTION GUIDE

MODEL	PART NUMBER	DESCRIPTION
LC117-020	65835	Temp Limit: 450°F, 30" capillary
LC117-040	68475	Temp Limit: 265°, 24" capillary
TB125-016	65826	Temp Range: 60°-250°F, 48" capillary
TB125-023	66544	Temp Range: 100°-220°, 24" capillary
TC125-025	67152	Temp Range: 200°-400°F, 36" capillary

NOTE: As the specifications vary by purchaser, the provided product drawings are samples of a diverse product offering.

PECO controls are intended for use as part of an engineered system, suitably enclosed and tested to assure safe, effective operation. The determination of specifications and applications is the responsibility of the purchaser.

L107 SERIES - Manual Reset High Limit Thermostat

The LA107 and LB107 are remote bulb temperature controls with single pole, single throw, manual reset contacts that open on temperature rise. Reset is accomplished by depressing the reset plunger. Both devices are trip-free; the switch contacts will open when the setting is exceeded even when the reset plunger is depressed and held. After a limit operation has opened the switch contacts, the temperature must drop below the setting before reset can be accomplished. The LA107 is a type M-1 device and will operate as an automatic reset control when the reset plunger is depressed and held. The LB107 is a type M-2 device and will not automatically reset even though the reset plunger is depressed and held.

Manual reset limit controls are recommended for situations in which the functioning of the limit may indicate the existence of a potentially overtemp condition. See applicable safety codes, UL, AGA, CSA, and other approval body publications for specific requirements. Equipment commonly using manual reset limit controls include: fryers, booster heaters, commercial water heaters, duct heaters, dishwashers, ovens, sterilizers, steamers, vending machines, coffee makers, immersion heaters, etc.

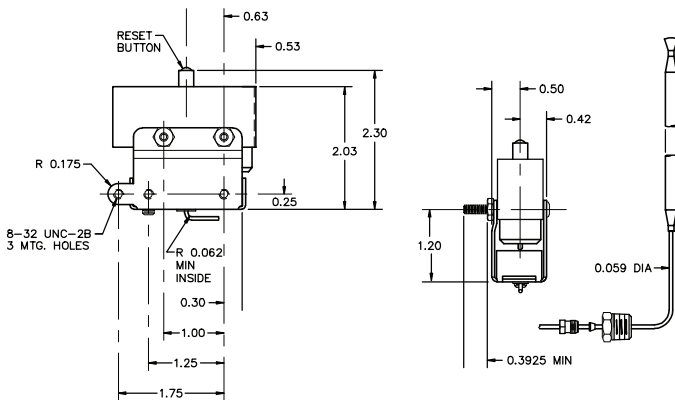

L117 SERIES - Commercial Grade High Limit Temperature Thermostat

The L117 series incorporates a negative bias temperature sensing element. The bulb and capillary type sensor accurately senses temperature at the bulb location to provide overtemperature protection. Additionally, if the unit is mechanically damaged resulting in loss of sensor fill fluid, such as by a broken capillary tube, the switch contacts will operate as if a high temperature condition has occurred.

These controls are available as type M1, M2 or automatic reset devices. M1 devices (LA117 series) are manual reset but will operate as an automatic reset control when the reset plunger is held depressed. M2 devices (LB117 series) are manual reset controls that will not automatically reset even though the reset plunger is held depressed. Automatic reset devices (LC117 series) will operate the contacts at the temperature setpoint and will automatically reset their contacts when the temperature is reduced. The L117 thermostats are all available with either line voltage or millivolt ratings.

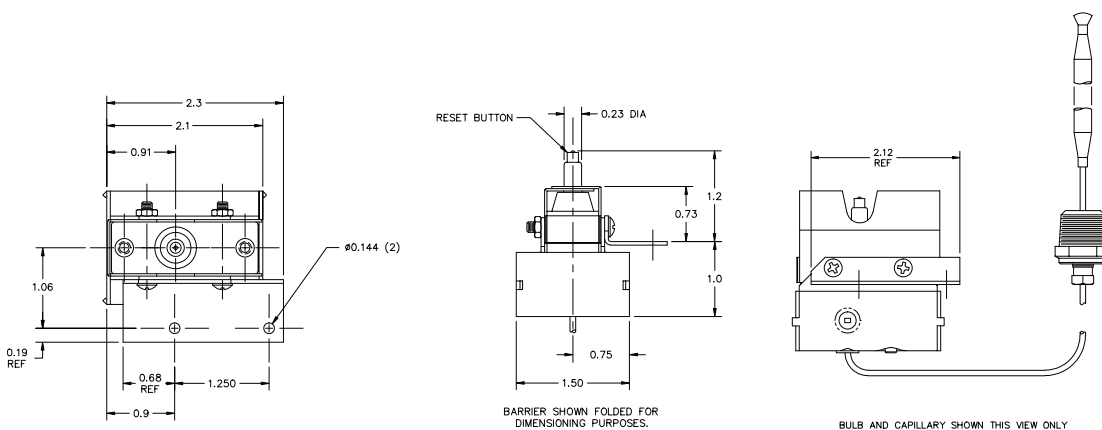

TEMPERATURE REGULATING AND LIMITING CONTROLS

TECHNICAL SPECIFICATIONS

	T103	T125	L107	L117
Temperature Range	-20° to 500°F/ -28° to 260°C	Various Ranges Available from 100° to 500°F/ 37° to 260°C	100° to 500°F/ 37° to 260°C	Various Ranges Available from 100° to 500°F/ 37° to 260°C
Bulb Diameters	Standard bulb diameters 3/16", 1/4", 5/16", 3/8"	Standard bulb diameters 3/16", 1/4", 5/16", 3/8"	Standard bulb diameters 3/16", 1/4", 5/16", 3/8"	Standard bulb diameters 3/16", 1/4", 5/16", 3/8"
Sensor Lengths	Standard capillary lengths to 10ft	Standard capillary lengths to 10ft	Standard capillary lengths up to 10ft	Standard capillary lengths up to 10ft
Shaft Configurations	Standard industry shaft configurations available	Standard industry shaft configurations available		
Switch	SPST, SPDT	SPST	SPDT, SP manual reset	SPDT, SP manual reset
Thermostat Mounting	1 5/16" mounting center	1 5/16" or 1 3/4" mounting centers	Various mounting centers available	Various mounting centers available
Agency Approvals	UL, CSA	UL, CSA, CE	UL, CSA	UL, CSA, CE

RATINGS

Model Number	Voltage	Non-Inductive (Amps)	Full Load (Amps)	Locked Rotor (Amps)	Pilot Duty
T103	120 VAC	22/ 25	4.4/ 16.0	26.4/ 80.0	125 VA
	208 VAC	22/ 25	4.0/ 13.2	24.0/ 66.0	125 VA
	240 VAC	22/ 25	3.6/ 12.0	21.6/ 60.0	125 VA
	277 VAC	18/ 22	3.0/ 10.0	18.0/ 50.0	125 VA
L107	120 VAC	30	13.8	82.8	125 VA
	240 VAC	30	10.0	60.0	125 VA
	277 VAC	30	8.3	49.8	125 VA
	480 VAC	20	---	---	125 VA
L117	120 VAC	30/ 30/ 25	9.8	58.8	250/ 250/ 125 VA
	240 VAC	30/ 30/ 25	8.0	48.0	250/ 250/ 125 VA
	277 VAC	30/ 30/ 22	6.6	39.6	250/ 250/ 125 VA
	480 VAC	10/ 10/ 5	---	---	250/ 250/ 125 VA
T125	120 VAC	25/ 30/ ---	16/ 16/ ---	80/ 80/ ---	125/ 125/ 50 VA
	240 VAC	25/ 30/ ---	12/ 12/ ---	60/ 60/ ---	125/ 125/ 50 VA
	277 VAC	22/ 30/ ---	10/ 10/ ---	50/ 50/ ---	125/ 125/ 50 VA
	480 VAC	---/ 20/ ---	---	---	---
	24 VAC	---	---	---	---/ ---/ 25 VA

TC125 - Millivolt - Suitable for 750 millivolt systems



Automation and Controls
 Division of PECO, Inc.
 PO Box 82189, Portland, OR 97282

Phone: 800-874-8547 / 503-233-6401
 Email: sales@pecomanufacturing.com
 www.pecomanufacturing.com